

Fiberdyne Configuration 88

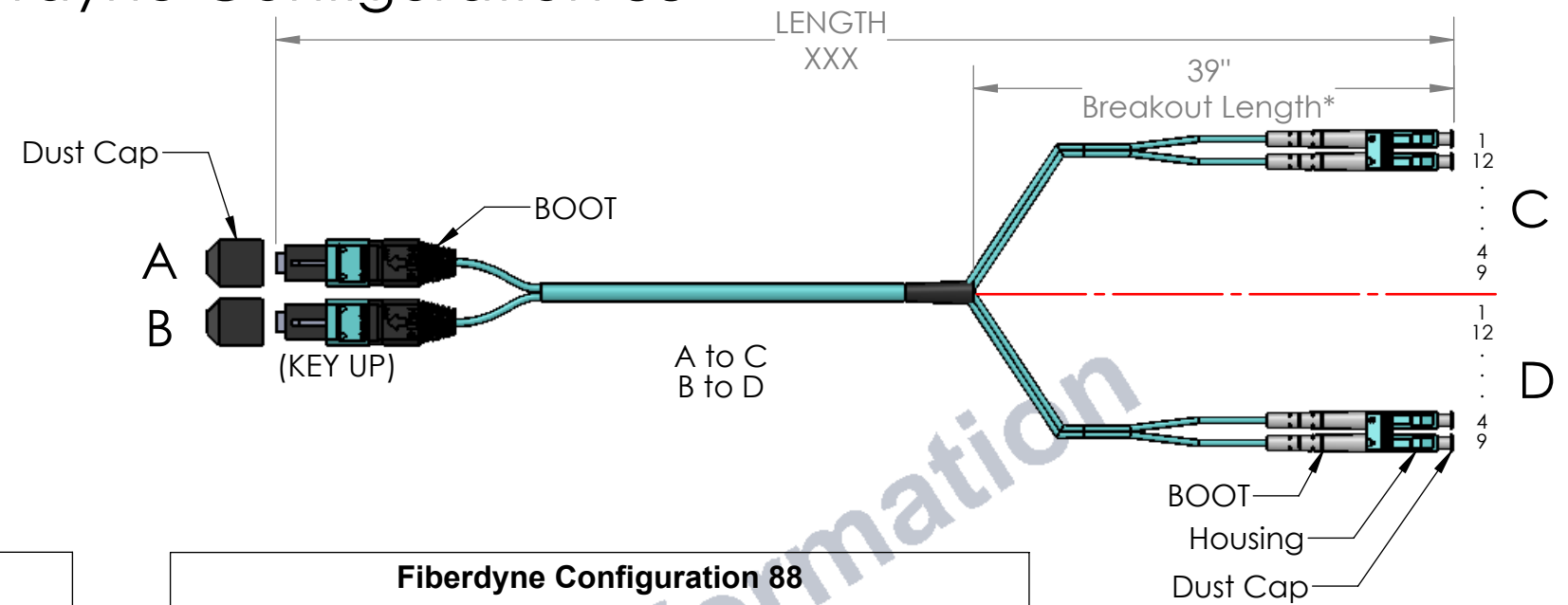
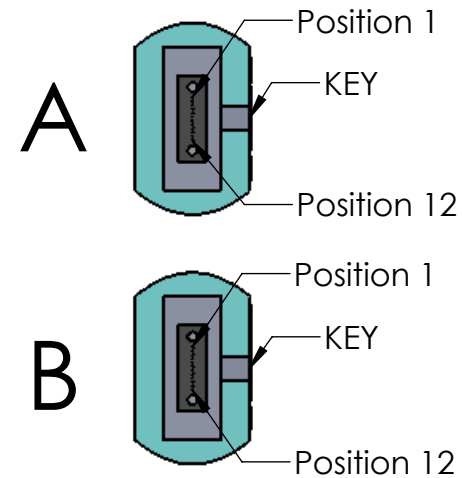

40Gb MPO Assemblies

Fiberdyne Part Number	Fiberdyne Configuration 88	Cable Type 50/125 OM3 (Max 100m)	Fiber Count	MPO End Connector	LC Connectors	Guide Pin P=Pinned(Male) NP=Non-Pinned(Female)	Insertion Loss (IL) Standard / Low Loss*
FMT-088010-XXXM	40GBASE-SR4	3mm Round Plenum OM3	24	MPO 1x12	Duplex LC	NP-NP	<.75
FMT-088020-XXXM	40GBASE-SR4	3mm Round Plenum OM3	24	MPO 1x12	Duplex LC	NP-P	<.75
FMT-088030-XXXM	40GBASE-SR4	3mm Round Plenum OM3	24	MPO 1x12	Duplex LC	P-NP	<.75
FMT-088040-XXXM	40GBASE-SR4	3mm Round Plenum OM3	24	MPO 1x12	Duplex LC	P-P	<.75
FMT-088050-XXXM	40GBASE-SR4	3mm Round Plenum OM3	24	MPO 1x12	Duplex LC	NP-NP	<.35
FMT-088060-XXXM	40GBASE-SR4	3mm Round Plenum OM3	24	MPO 1x12	Duplex LC	NP-P	<.35
FMT-088070-XXXM	40GBASE-SR4	3mm Round Plenum OM3	24	MPO 1x12	Duplex LC	P-NP	<.35
FMT-088080-XXXM	40GBASE-SR4	3mm Round Plenum OM3	24	MPO 1x12	Duplex LC	P-P	<.35
Fiberdyne Part Number	Fiberdyne Configuration 88	Cable Type 50/125 OM4 (Max 150m)	Fiber Count	MPO End Connector	LC Connectors	Guide Pin P=Pinned(Male) NP=Non-Pinned(Female)	Insertion Loss (IL) Standard / Low Loss*
FMT-088110-XXXM	40GBASE-SR4	3mm Round Plenum OM4	24	MPO 1x12	Duplex LC	NP-NP	<.75
FMT-088120-XXXM	40GBASE-SR4	3mm Round Plenum OM4	24	MPO 1x12	Duplex LC	NP-P	<.75
FMT-088130-XXXM	40GBASE-SR4	3mm Round Plenum OM4	24	MPO 1x12	Duplex LC	P-NP	<.75
FMT-088140-XXXM	40GBASE-SR4	3mm Round Plenum OM4	24	MPO 1x12	Duplex LC	P-P	<.75
FMT-088150-XXXM	40GBASE-SR4	3mm Round Plenum OM4	24	MPO 1x12	Duplex LC	NP-NP	<.35
FMT-088160-XXXM	40GBASE-SR4	3mm Round Plenum OM4	24	MPO 1x12	Duplex LC	NP-P	<.35
FMT-088170-XXXM	40GBASE-SR4	3mm Round Plenum OM4	24	MPO 1x12	Duplex LC	P-NP	<.35
FMT-088180-XXXM	40GBASE-SR4	3mm Round Plenum OM4	24	MPO 1x12	Duplex LC	P-P	<.35

*Insertion Loss for Connector Only

Fiberdyne Configuration 88

MPO-LC, Two 12 Pin 8 Fiber MPO to Two Groups of 8 LC, 40G, Method A, 2mm Breakout					
Fiber Color Connector	Lane Assignment Connector A	Pin # Connector A	Breakout C, LC, Pin Polarity	Lane Assignment Connector C	Fiber Color Connector
Blue	TX1	1	1	RX1	Blue
Orange	TX2	2	2	RX2	Orange
Green	TX3	3	3	RX3	Green
Brown	TX4	4	4	RX4	Brown
Grey	Not Used	5	5	Not Used	Grey
White	Not Used	6	6	Not Used	White
Red	Not Used	7	7	Not Used	Red
Black	Not Used	8	8	Not Used	Black
Yellow	RX4	9	9	TX4	Yellow
Purple	RX3	10	10	TX3	Purple
Pink	RX2	11	11	TX2	Pink
Aqua	RX1	12	12	TX1	Aqua

*Pin configuration shown also applies to MPO A to group C of 8 LCs

*-39" standard breakout length, custom lengths available
-Custom Connectors also available

RoHS

Fiberdyne Labs Inc. Frankfort, NY
www.fiberdyne.com

PROPRIETARY AND CONFIDENTIAL
THE INFORMATION CONTAINED IN THIS DRAWING IS THE SOLE PROPERTY OF Fiberdyne Labs Inc. ANY REPRODUCTION IN PART OR AS A WHOLE WITHOUT THE WRITTEN PERMISSION OF Fiberdyne Labs Inc IS PROHIBITED.

FIBERDYNE LABS INC.		
TITLE: Fiberdyne Configuration 88		
MPO-LC, Two 12 Pin 8 Fiber MPO to Two Groups of 8 LC, 40G		
Method A		
SIZE B	DWG. NO. 075-11813-001	REV A
SCALE: 1:1	ECR: 14006-001	SHEET 1 OF 1